

Section 1A
Scale: 1" = 1'-0"

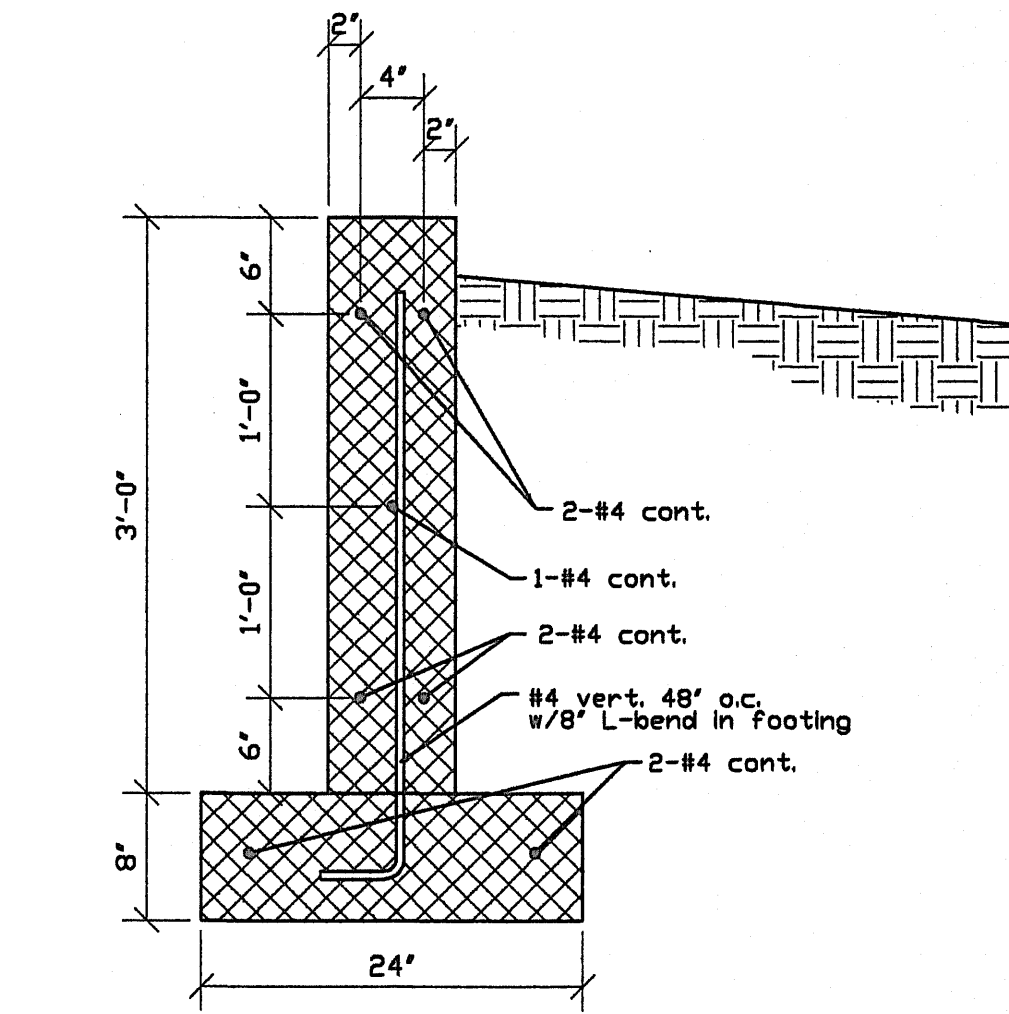

Section 2
Scale: 1" = 1'-0"

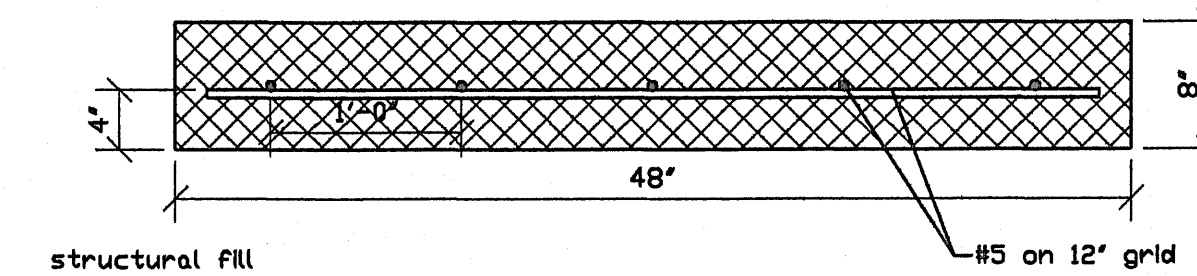

Section 4
Scale: 1" = 1'-0"

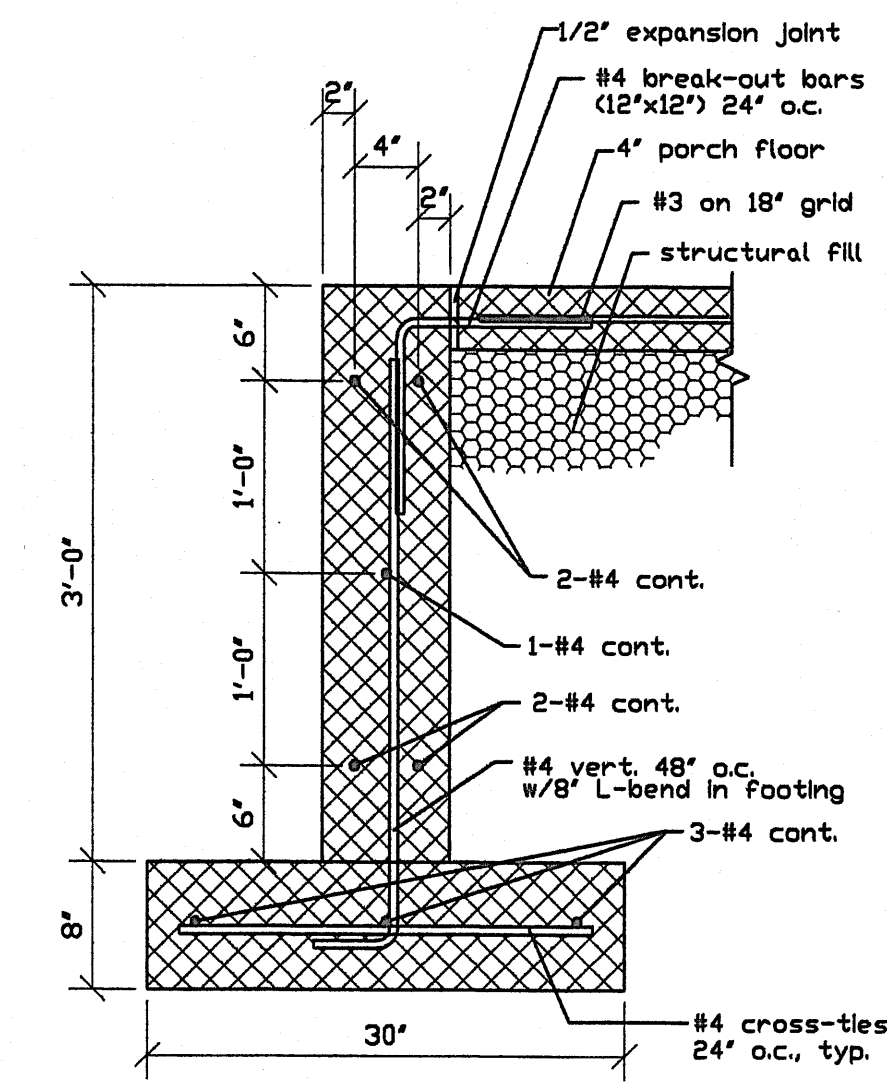

Section 1B
Scale: 1" = 1'-0"

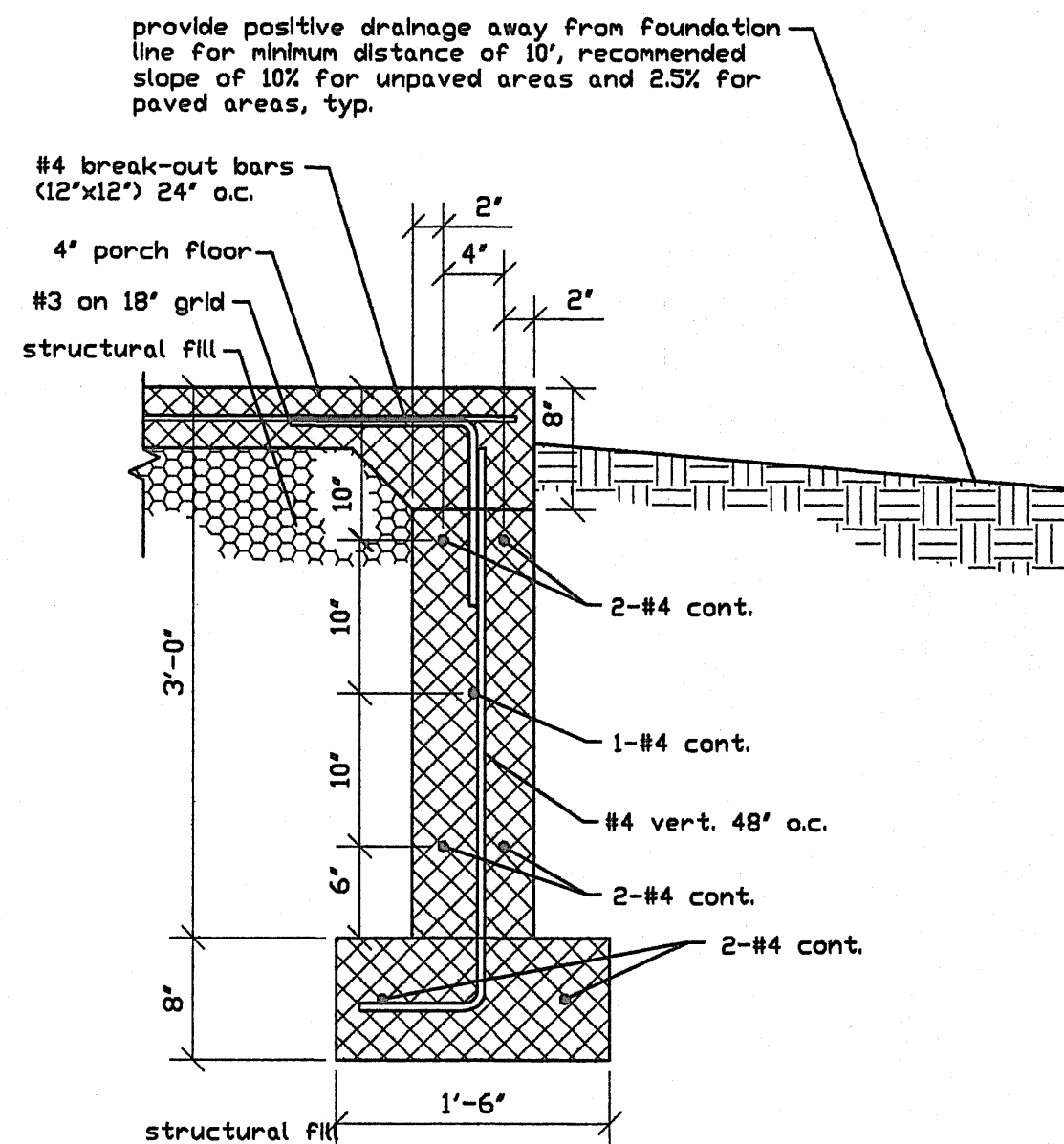

Section 3
Scale: 1" = 1'-0"

provide positive drainage away from foundation line for minimum distance of 10', recommended slope of 10% for unpaved areas and 2.5% for paved areas, typ.

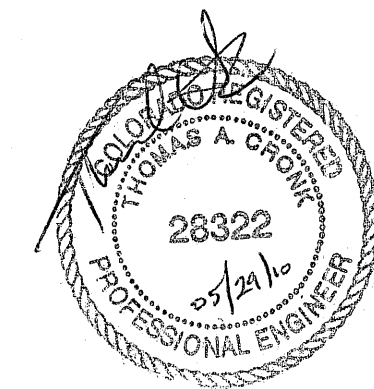

| REVISIONS | DATE | REMARKS | BY |
|-----------|------|---------|----|
| | | | |
| | | | |
| | | | |
| | | | |

UNIVERSITY VILLAGE APTS - UNIT C
Foundation Details
2340 N 17th Street
Grand Junction, CO 81501

PRECISION CONSTRUCTION
2992 North Avenue
Grand Junction, CO 81504
970-243-3355

ENGINEERING DESIGN BY
CCI ENGINEERING
CRONK CONSTRUCTION INC.
THOMAS A. CRONK
28322
05/26/10
PROFESSIONAL ENGINEER

PROJECT
Univ. Village #C
foundation dis.

SCALE
as shown

DATE DRAWN
05/26/10

LATEST REVISION
NO REVISION

SHEET **S2** OF